

*1	Turbofilteranlage	Turbo filter system	Installation de turbofiltre	Turbofiltro	Turbofilter-installatie	Turbofilter-anläggning
*2	Bandfilteranlage	Band filter system	Installation de filtre de bande	Filtro passabanda	Bandfilter-installatie	Bandfilter-anläggning
*3	Siebfilteranlage	Screen filter system	Installation de filtre à tamis	Filtro a rete	Zeeffilter-installatie	Silfilter-anläggning
*4	Tür für Werkzeugbestückung	Door for tooling	Porte pour mise en place de l'outil	Porta per applicazione attrezzi	Deur voor werktuig-uitrusting	Dörr för verktygs-bestyckning
*5	Maschinengrundriss	Machine outline	Projection horizontale de la machine	Pianta della macchina	Machine-plattegrond	Maskinritning
*6	Spänebehälter	Swarf container	Récipient à copeaux	Contenitore per trucioli	Spanenbak	Span-behallare
*7	Späneförderer	Swarf conveyor	Convoyeurs de copeaux	Transportatore di trucioli	Spaan-transporteur	Span-transportör

Lieferung erfolgt nach  Ausführung:

Typ	A	B	C	D
Siebfilteranlage 350 L	1260	850	1800	11100
Bandfilteranlage 780 L	2460	900	2100	11400
Bandfilteranlage 1250 L	2950	1200	2700	12000
Turbofilteranlage 1000 L	2300	1500	2700	12000
Turbofilteranlage 2000 L	2700	1500	2700	12000

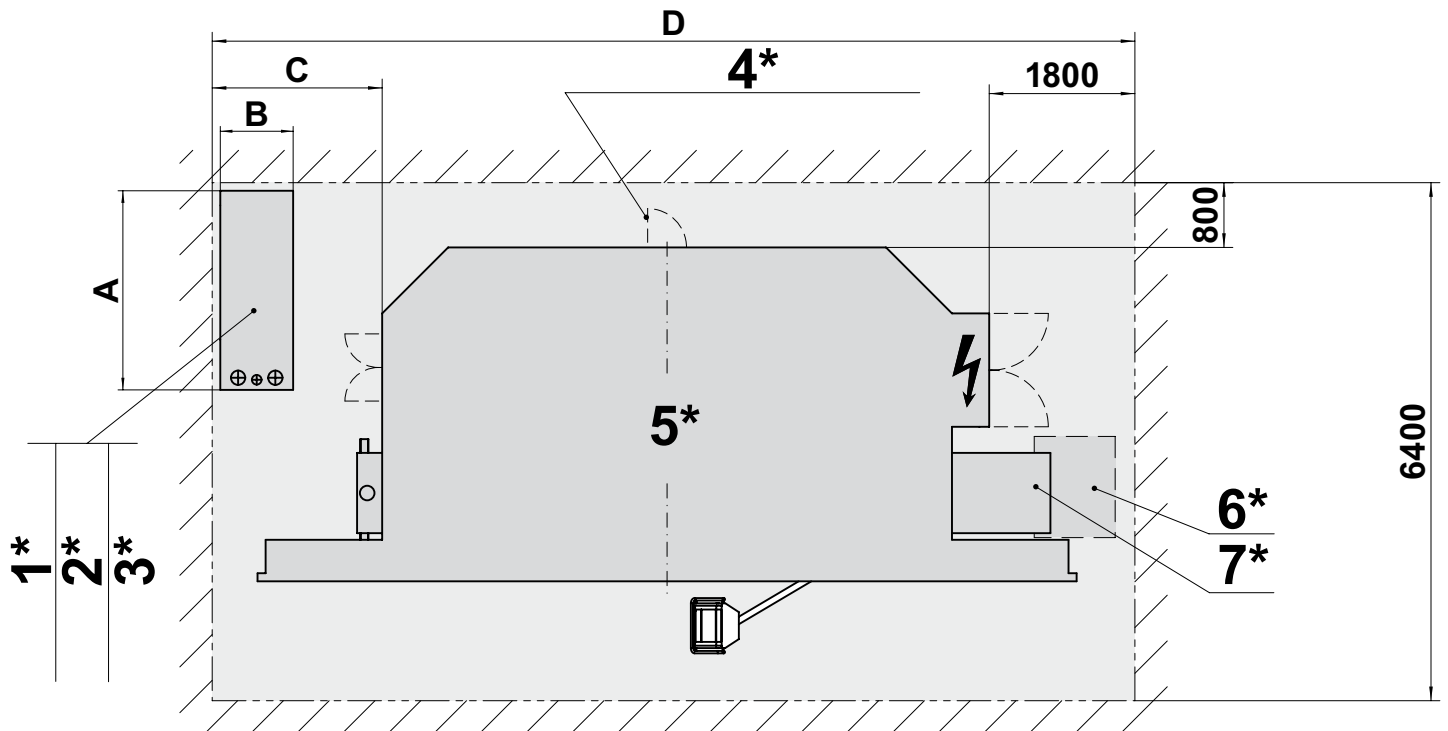

*1	Turbofilteranlage	Turbo filter system	Installation de turbofiltre	Turbofiltro	Turbofilter-installatie	Turbofilter-anläggning
*2	Bandfilteranlage	Band filter system	Installation de filtre de bande	Filtro passabanda	Bandfilter-installatie	Bandfilter-anläggning
*3	Siebfilteranlage	Screen filter system	Installation de filtre à tamis	Filtro a rete	Zeefilter-installatie	Silfilter-anläggning
*4	Tür für Werkzeugbestückung	Door for tooling	Porte pour mise en place de l'outil	Porta per applicazione attrezzi	Deur voor werktuig-uitrusting	Dörr för verktygs-bestyckning
*5	Maschinengrundriss	Machine outline	Projection horizontale de la machine	Pianta della macchina	Machine-plattegrond	Maskinritning
*6	Spänebehälter	Swarf container	Réceptier à copeaux	Contenitore per trucioli	Spanenbak	Span-behallare
*7	Späneförderer	Swarf conveyor	Convoyeurs de copeaux	Transportatore di trucioli	Spaan-transporteur	Span-transportör

Lieferung erfolgt nach  Ausführung:

Typ	A	B	C	D
Siebfilteranlage 350 L	1260	850	1800	11100
Bandfilteranlage 780 L	2460	900	2100	11400
Bandfilteranlage 1250 L	2950	1200	2700	12000
Turbofilteranlage 1000 L	2300	1500	2700	12000
Turbofilteranlage 2000 L	2700	1500	2700	12000