

Angled milling head SK40/SK40 (8423)

C60 -8000 rpm
RS60 -8000 rpm
C80 -8000 rpm
RS80 -8000 rpm

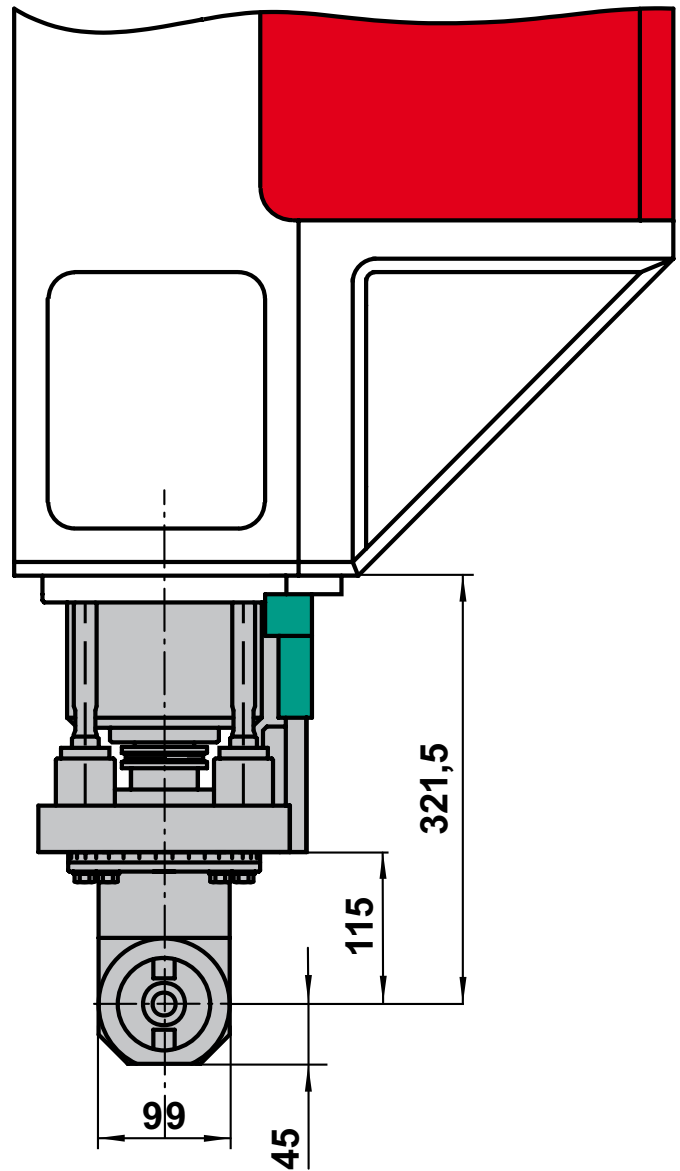
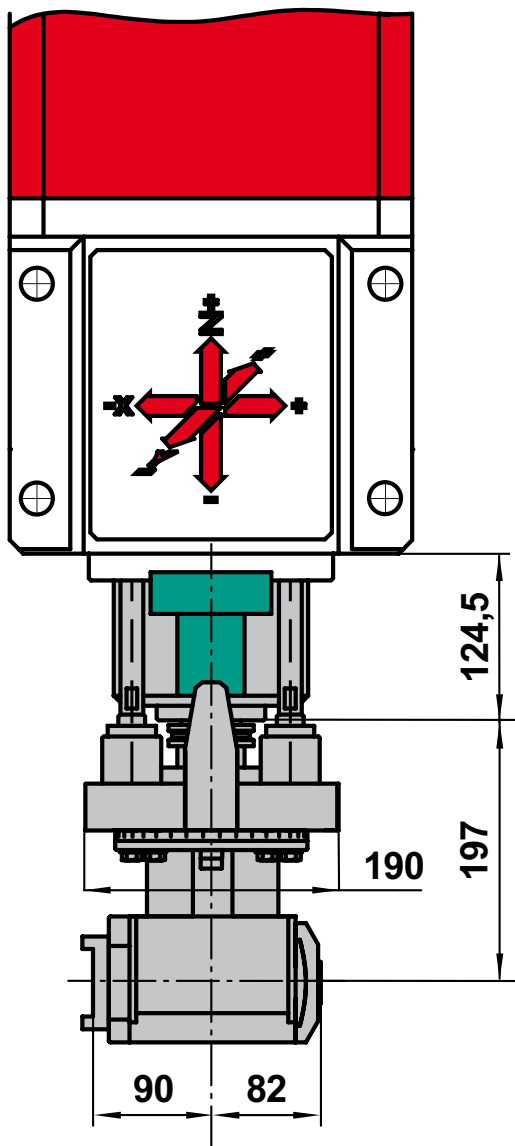

Angled milling head SK40/SK40 (30233a)

with internal coolant feed

C60 -8000 rpm

RS60 -8000 rpm

C80 -8000 rpm

RS80 -8000 rpm

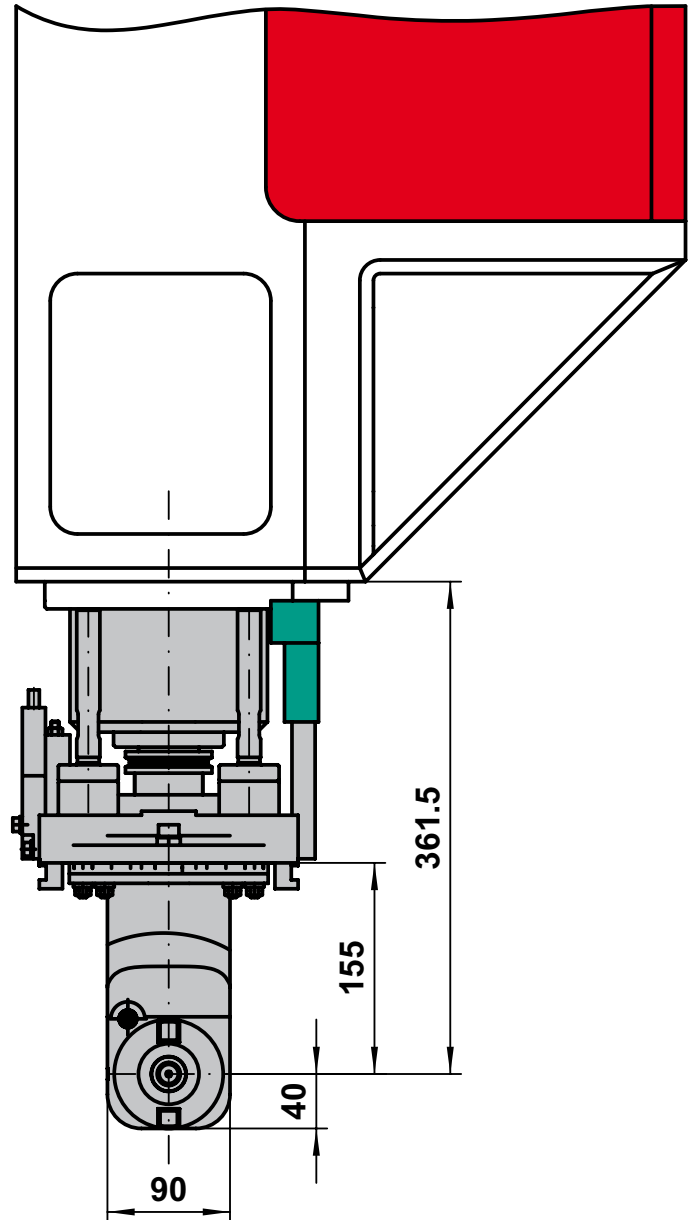
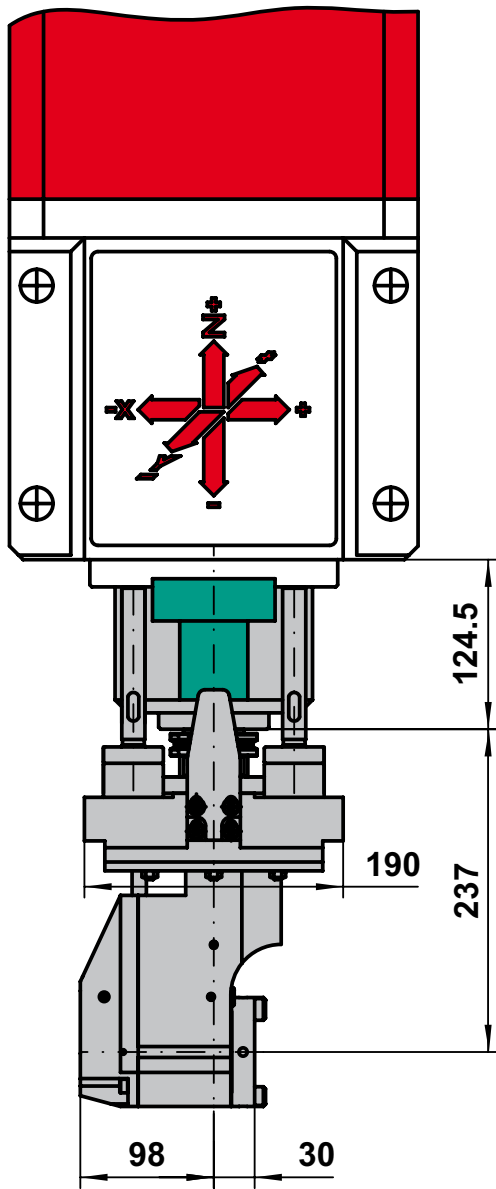

Angled milling head SK40/SK40 (8405)

CI100 -8000 rpm

CI25 -8000 rpm

RSI100 C40 -7000 rpm

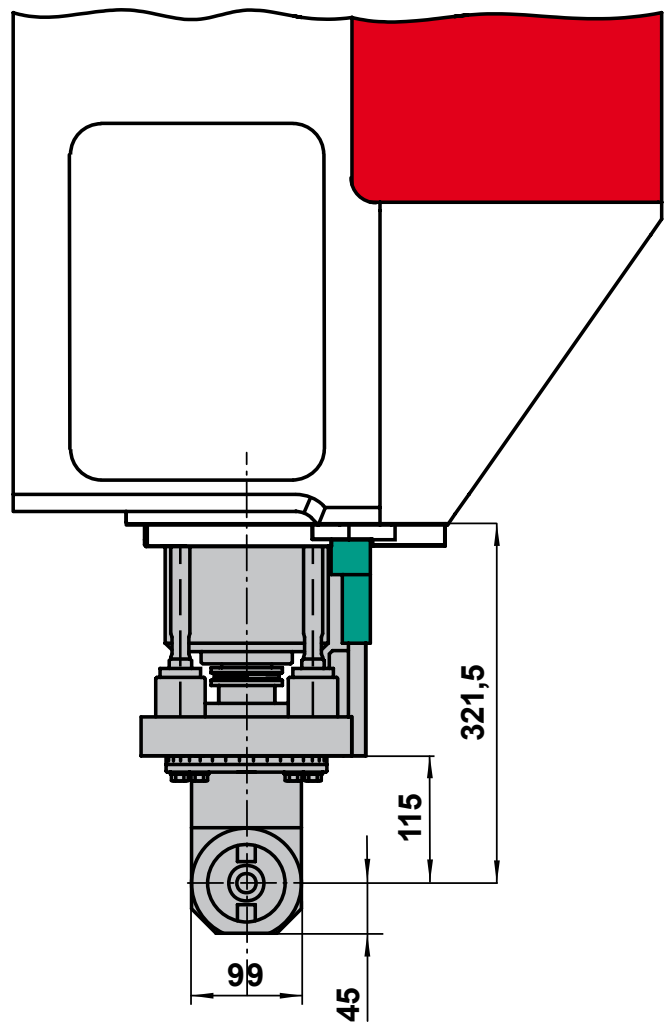
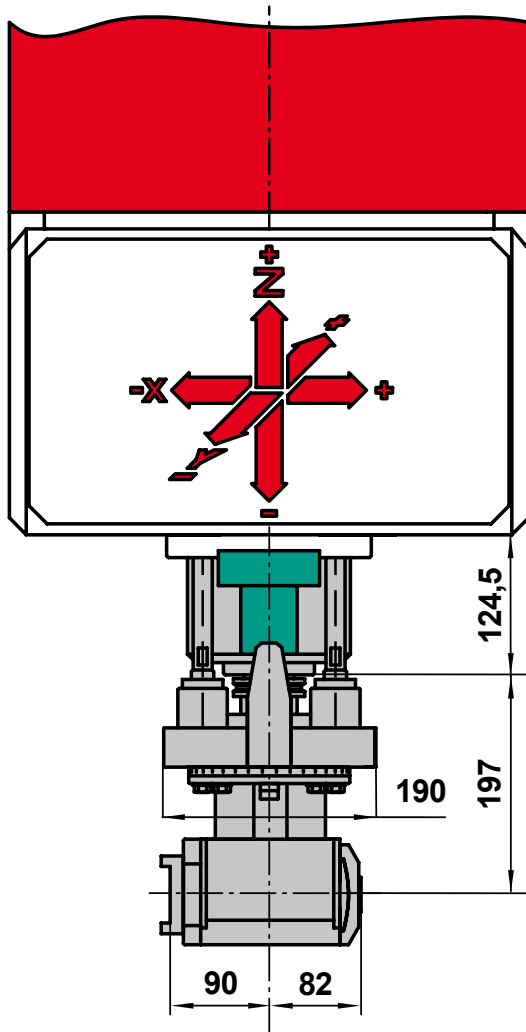

Angled milling head SK40/SK40 (10806a)

with internal coolant feed

CI100 -8000 rpm

CI25 -8000 rpm

RSI100 C40 -7000 rpm

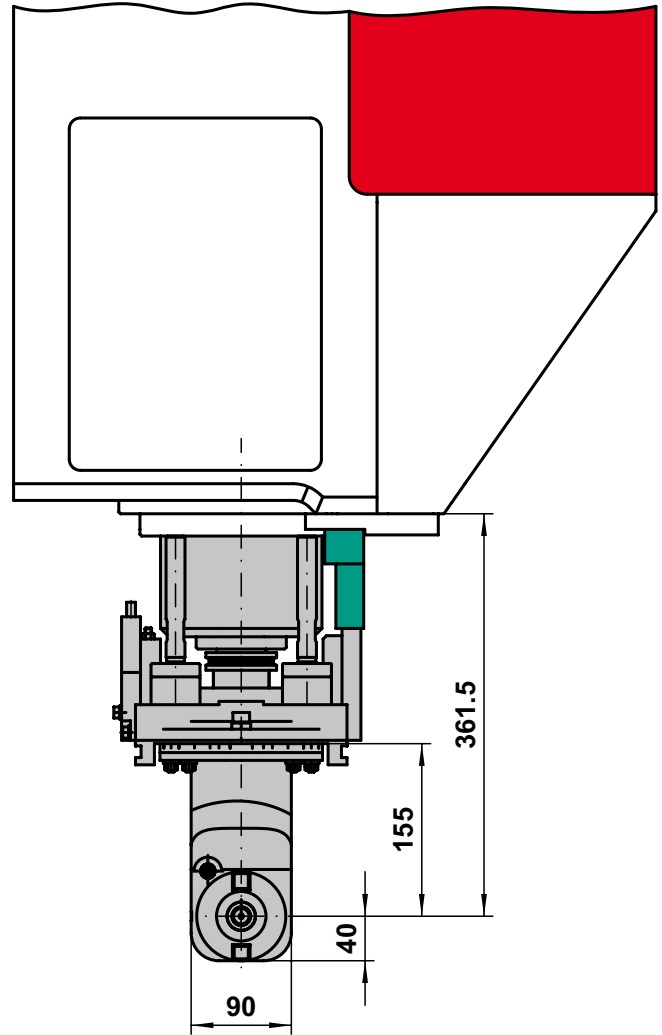
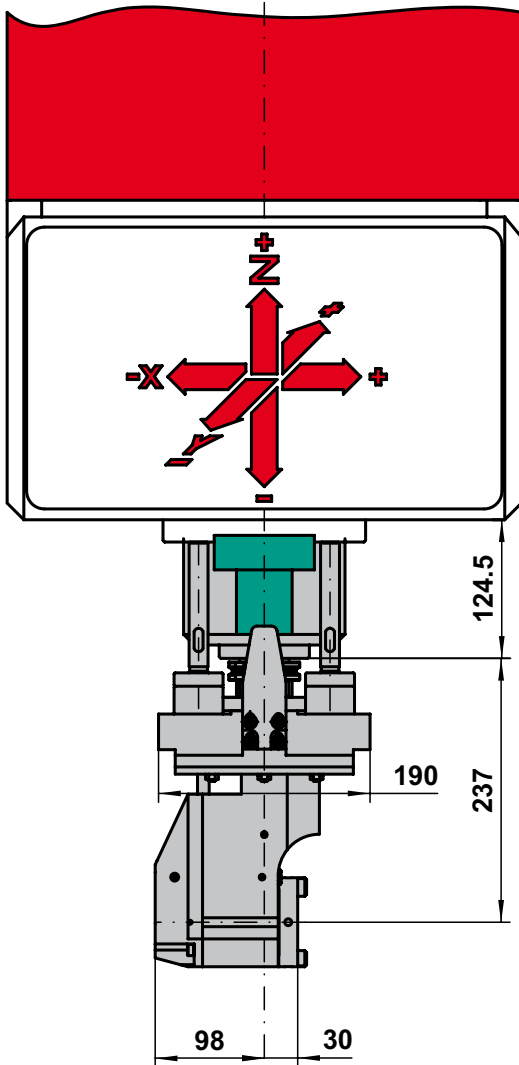

Angled milling head SK50/SK40 (8401)

BC100 -4500/6000 rpm
BC125 -6000/7000 rpm
RSI100K/L -7000 rpm
RSI25K -7000 rpm

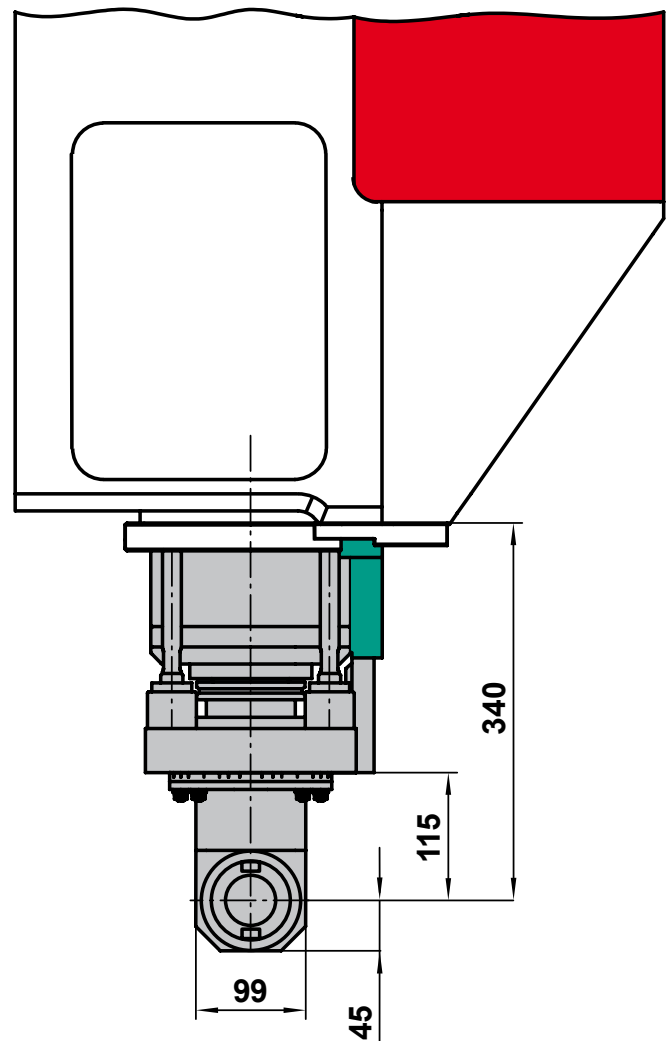
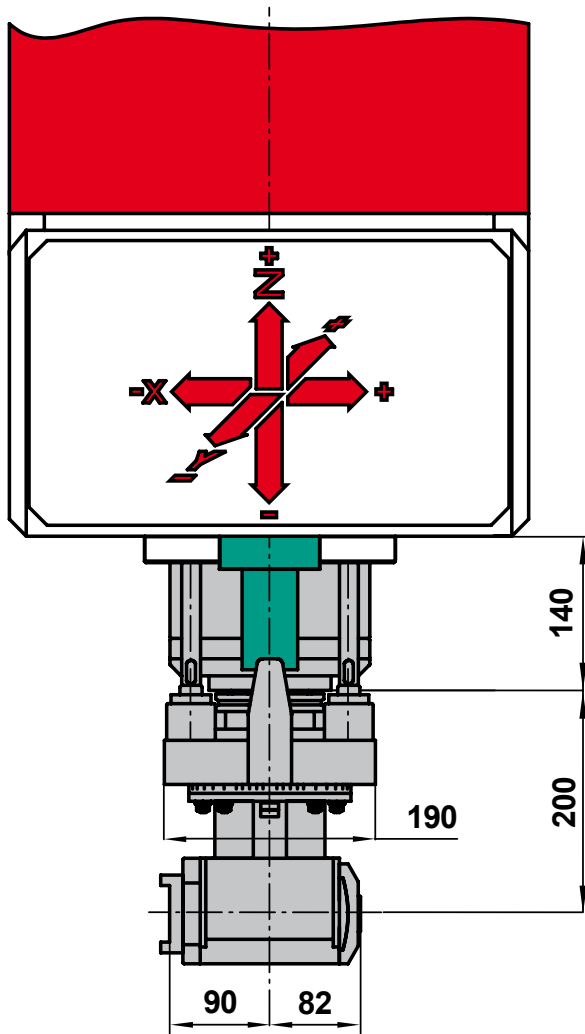

Angled milling head SK50/SK40 (10805a)

with internal coolant feed

BC100 -4500/6000 rpm

BC125 -6000/7000 rpm

RSI100K/L -7000 rpm

RSI25K -7000 rpm

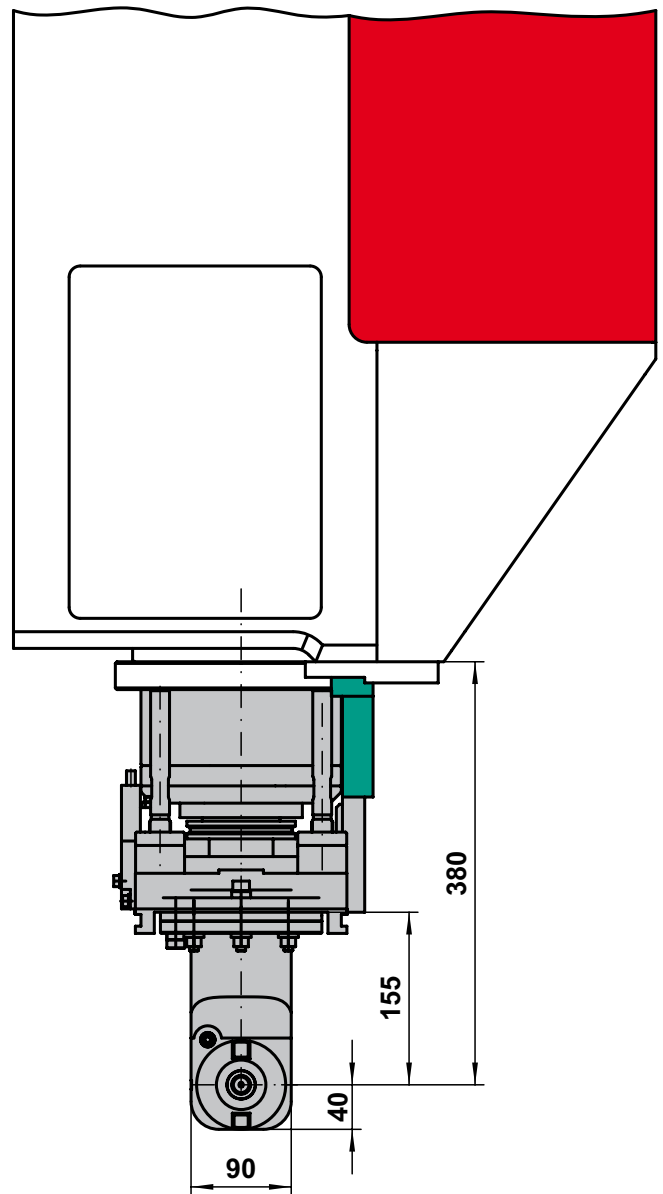
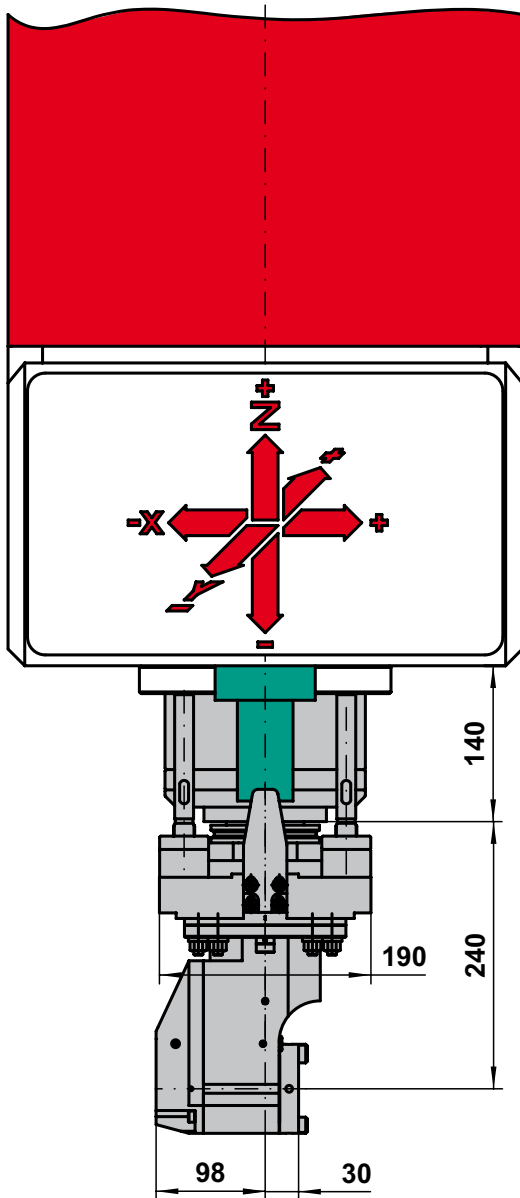

Dual angled drill head SK40/ER32 (4827a)

C60 -8000 rpm
RS60 -8000 rpm
C80 -8000 rpm
RS80 -8000 rpm

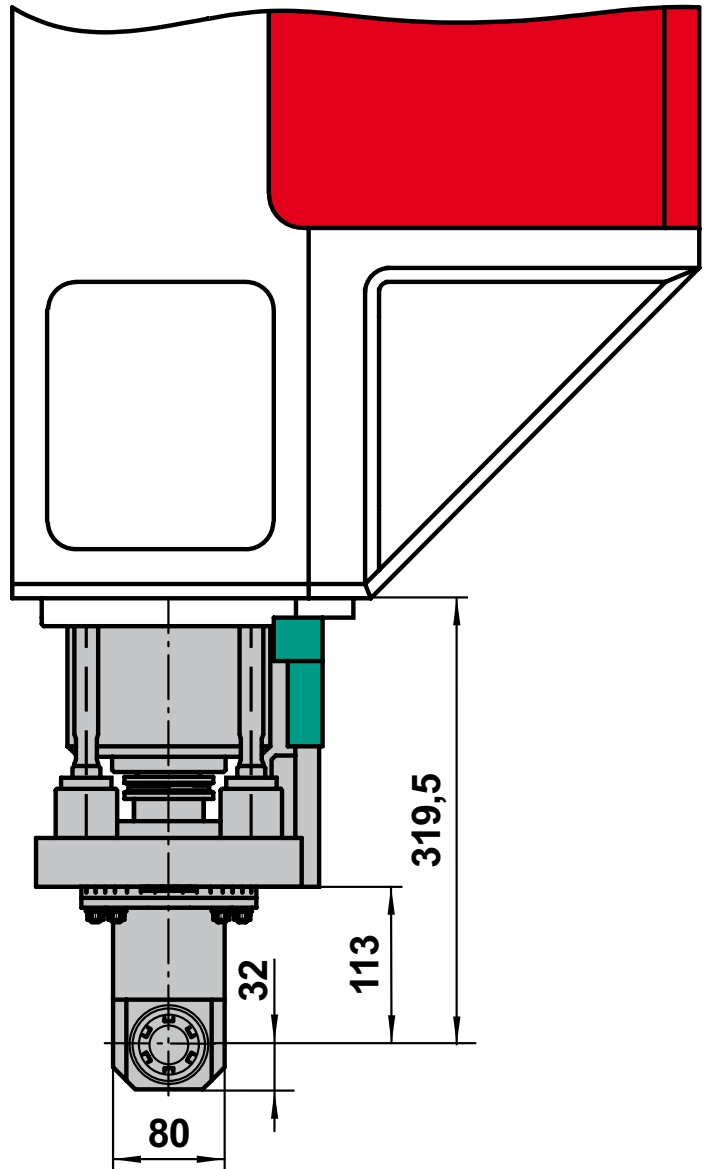
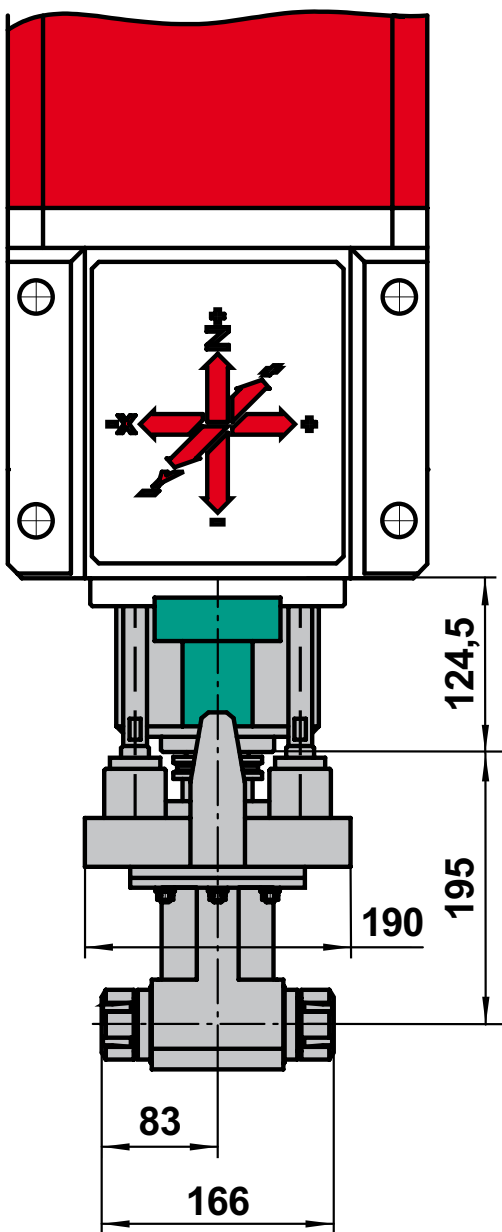

Dual angled drill head SK40/ER32 (8420a)

CI100 -8000 rpm
CI25 -8000 rpm
RSI100 C40 -7000 rpm

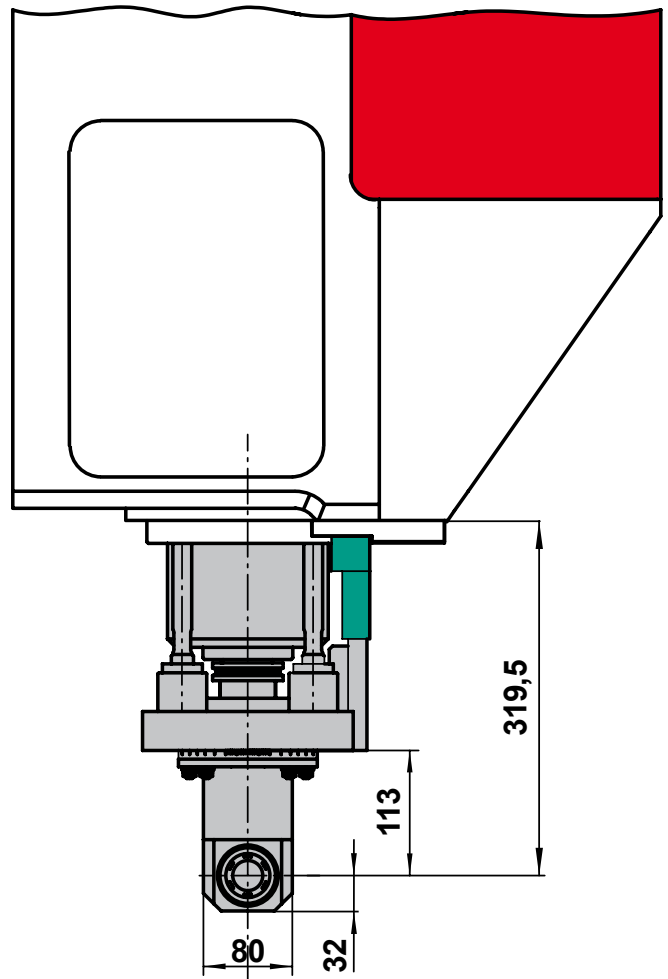
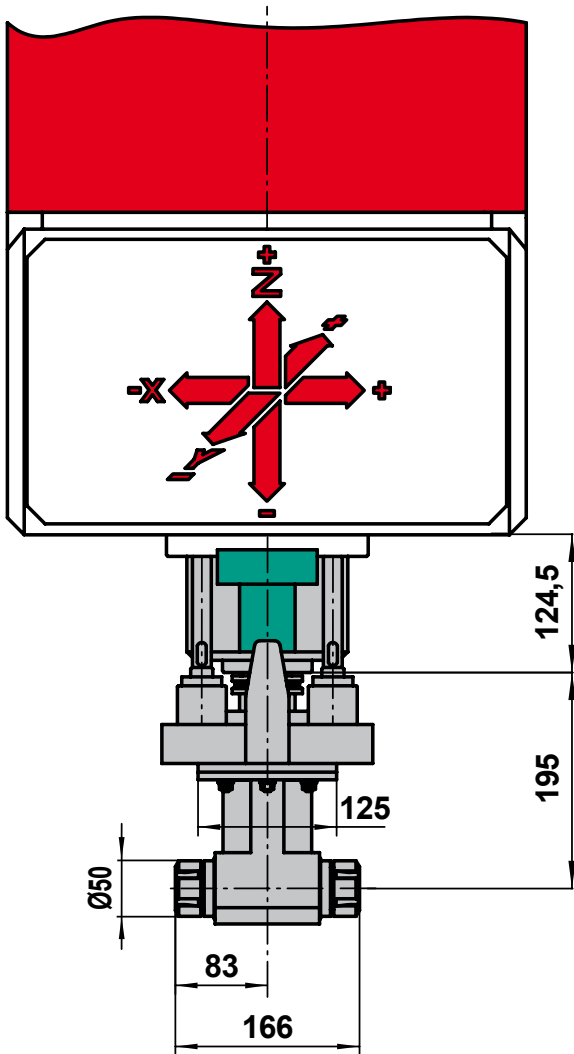

Dual angled drill head SK50/ER40 (8393)

BC100 -4500/6000 rpm
BC125 -6000/7000 rpm
RSI00K/L -7000 rpm
RSI25K -7000 rpm

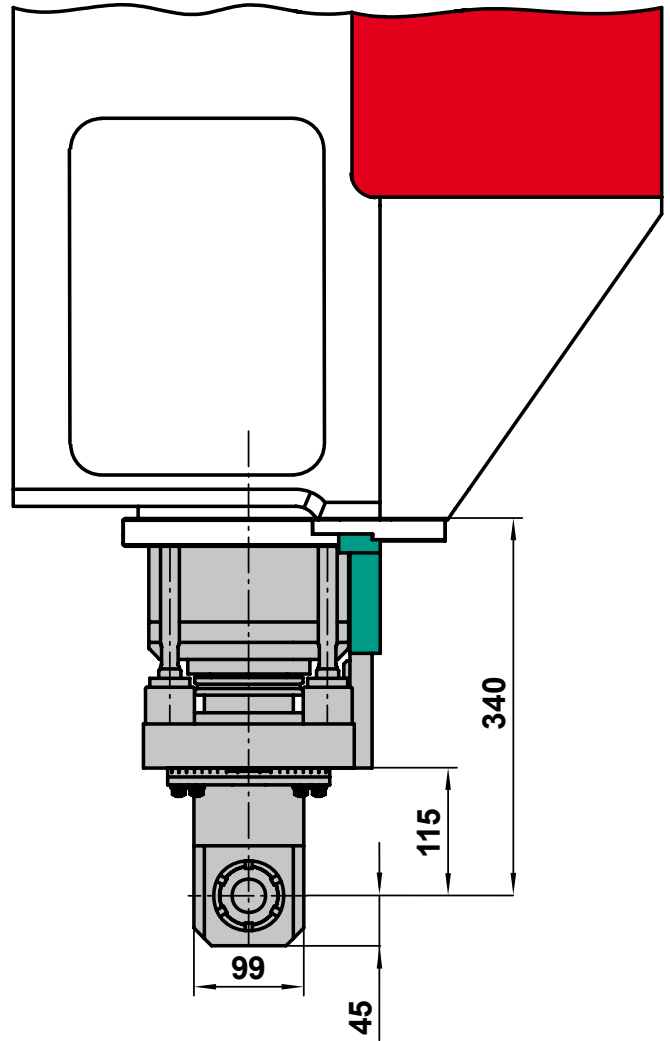
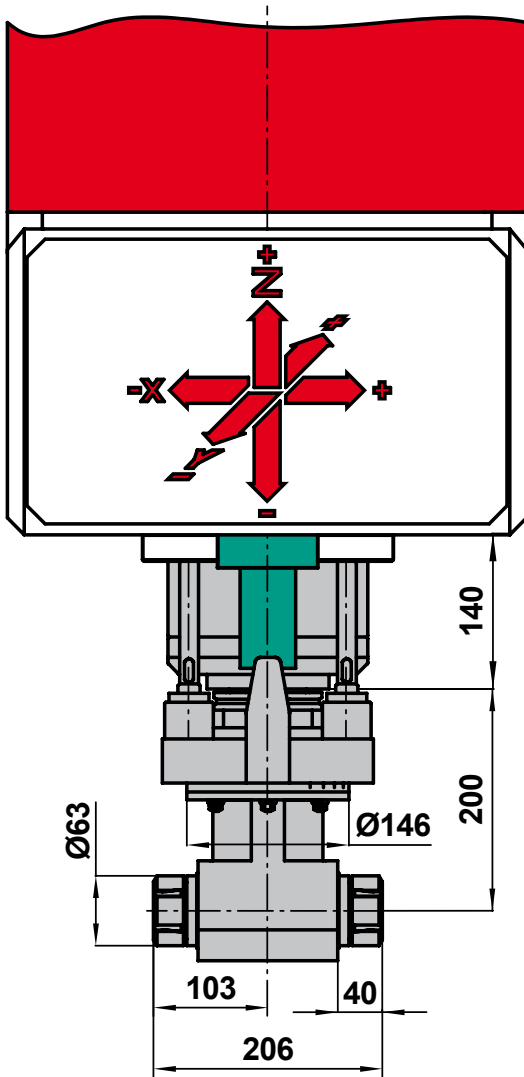

Tilting angled drill head SK40/ER32 (8432)

C60 -8000 rpm
RS60 -8000 rpm
C80 -8000 rpm
RS80 -8000 rpm

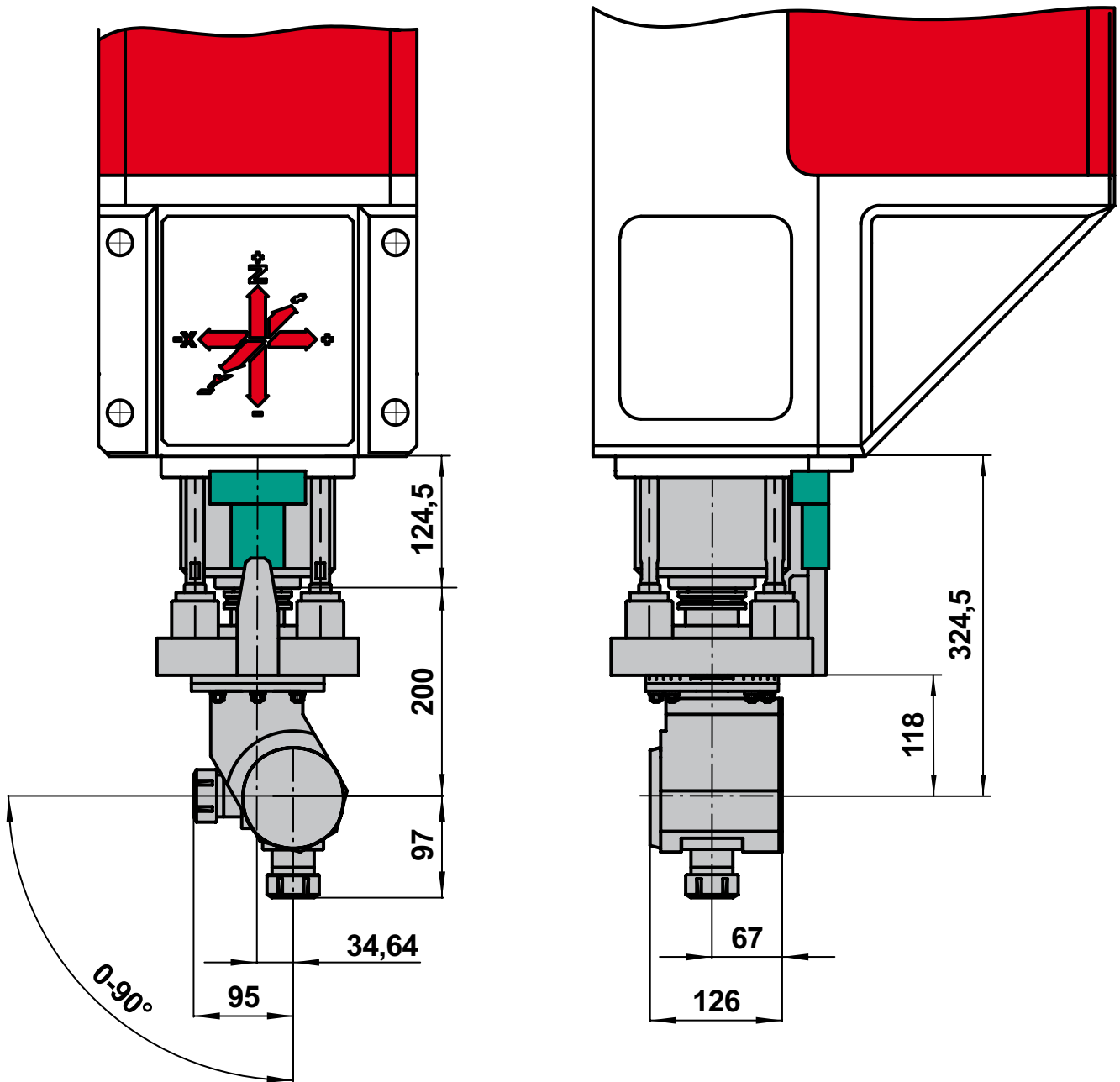

Tilting angled drill head SK50/ER40 (8431)

- BC100 -4500/6000 rpm
- BC125 -6000/7000 rpm
- RSI00K/L -7000 rpm
- RSI25K -7000 rpm

