

Anschluß an  
Maschinenrückseite

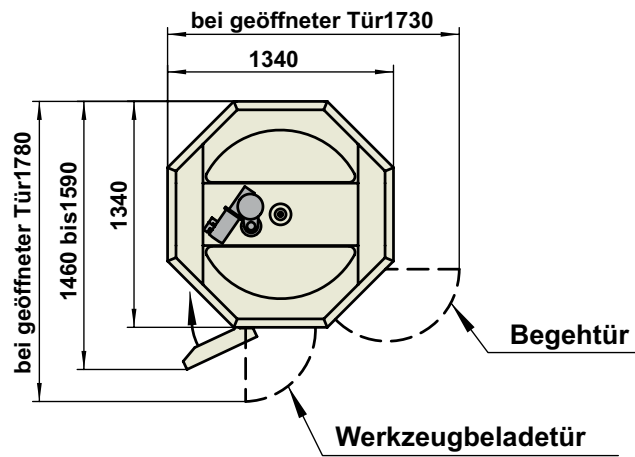

Werkzeugliste		
Werkzeugkapazität		III
Ebene	Anzahl	max. Länge
1	21	370
2	18	290
3	15	290
4	15	290
5	18	290
6	24	290