

Anschluß an
Maschinenrückseite

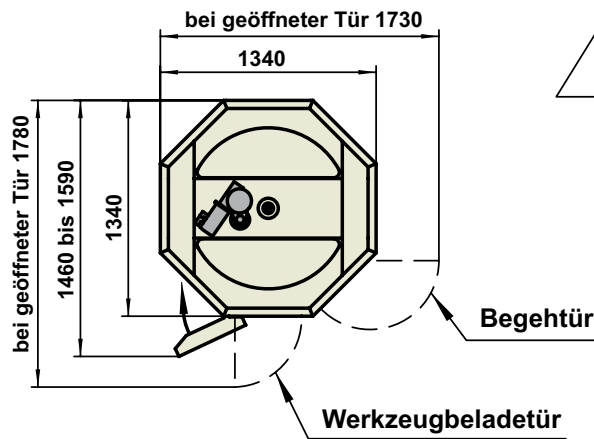

Werkzeugliste		
Werkzeugkapazität		190
Ebene	Anzahl	max. Länge
1	35	330
2	30	330
3	25	330
4	30	240
5	30	240
6	40	240

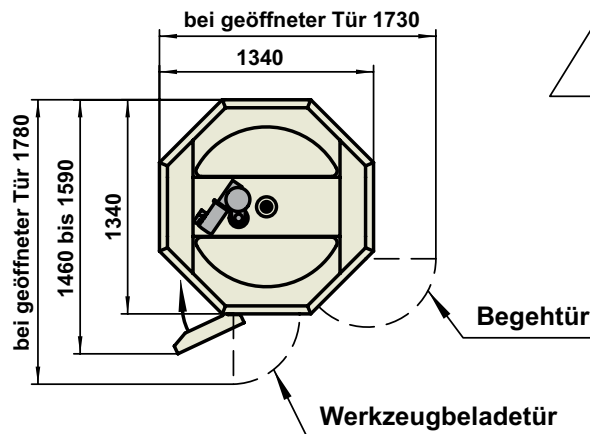
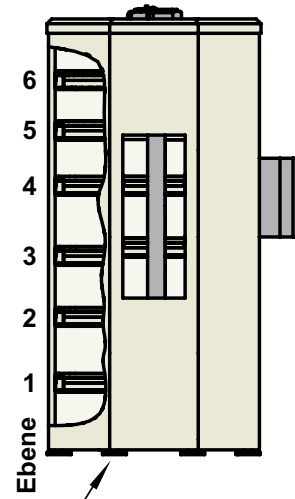
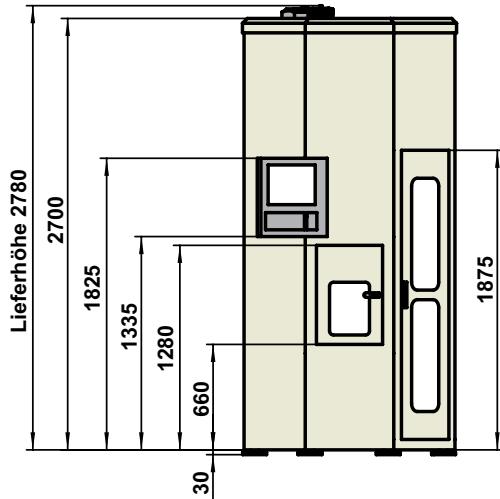

Anschluß an
Maschinenrückseite

Werkzeugliste		
Werkzeugkapazität		190
Ebene	Anzahl	max. Länge
1	35	250
2	30	250
3	25	250
4	25	250
5	35	250
6	40	250