

Anschluß an
Maschinenrückseite

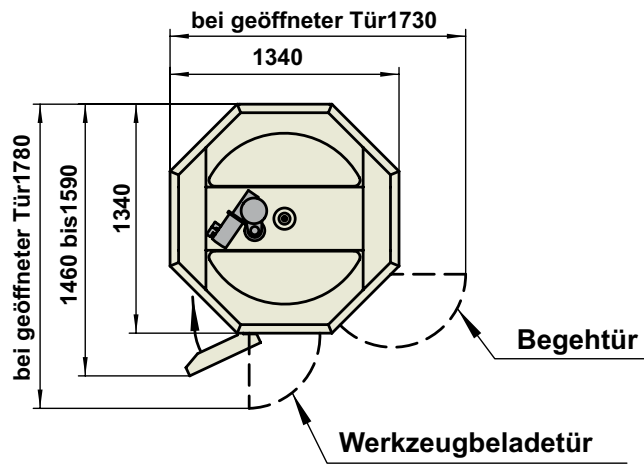

Werkzeugliste		
Werkzeugkapazität		114
Ebene	Anzahl	max. Länge
1	21	330
2	18	250
3	15	250
4	18	250
5	18	250
6	24	250